

AIRBLAST HYDRAULIC OIL COOLER HC14

Hydraulic, airblast cooler

The HC14 is a compact, integrated, hydraulic cooler complete with all ancillaries. This product is particularly suitable for many hydraulic transport applications. A unique feature of this cooler is the hydraulic built in test point from which you are instantly able to obtain the system working pressure.

Product features

- Easy to locate and fit
- Excellent cooling performance
- Compact design
 - Corrosion proof stainless steel construction
 - Return line filter
 - High efficiency centrifugal fan
 - Pressure relief valve
 - Fan speed control valve
 - 3rd line drain connection
 - Minimal maintenance
 - Excellent reliability

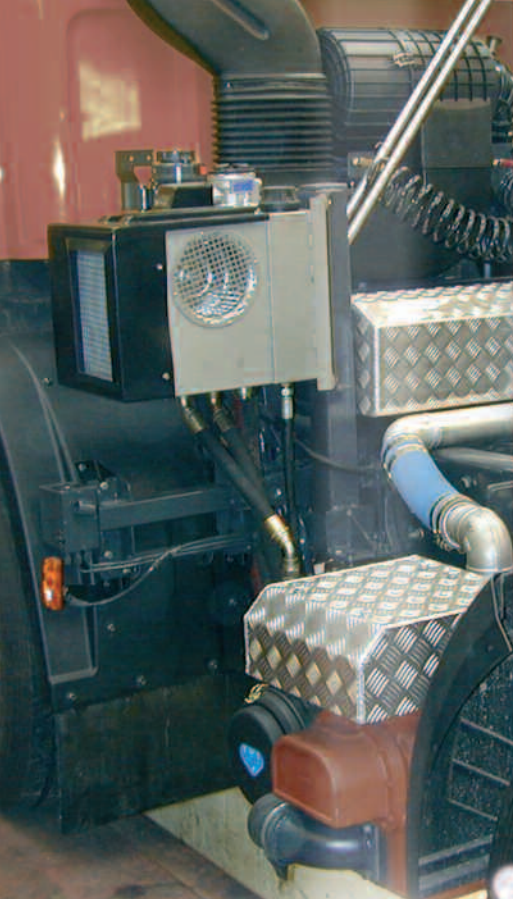

AIRBLAST HYDRAULIC OIL COOLER HC14

TECHNICAL SPECIFICATIONS

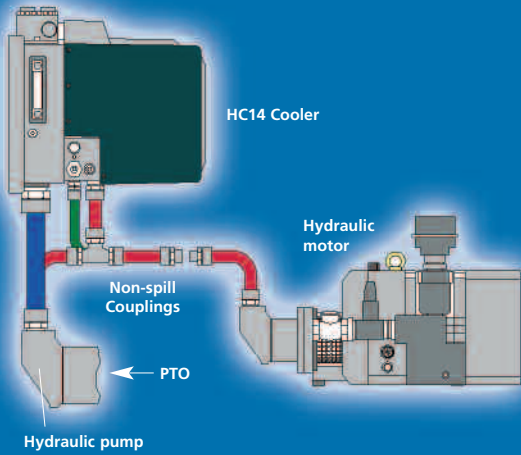

Hydraulic flow rate	80 to 160 litres/minute
Hydraulic pressure	40 to 315 bar
Fan Motor speed	2500 rpm (3000 rpm max.)
Heat dissipation max.	13.8 kW
Oil tank capacity	14 litres
Return line filtration	25µ

FEATURES

- Robust stainless steel construction
- Manual, electrical or pneumatic on/off valve
- Integral temperature & level gauge
- Hydraulic test point
- Return line filter pressure indicator
- Centrifugal steel fan for high efficiency
- Pressure relief valve
- Fan speed control valve

HC14 Cooler Dimensions
Weight: 35kg

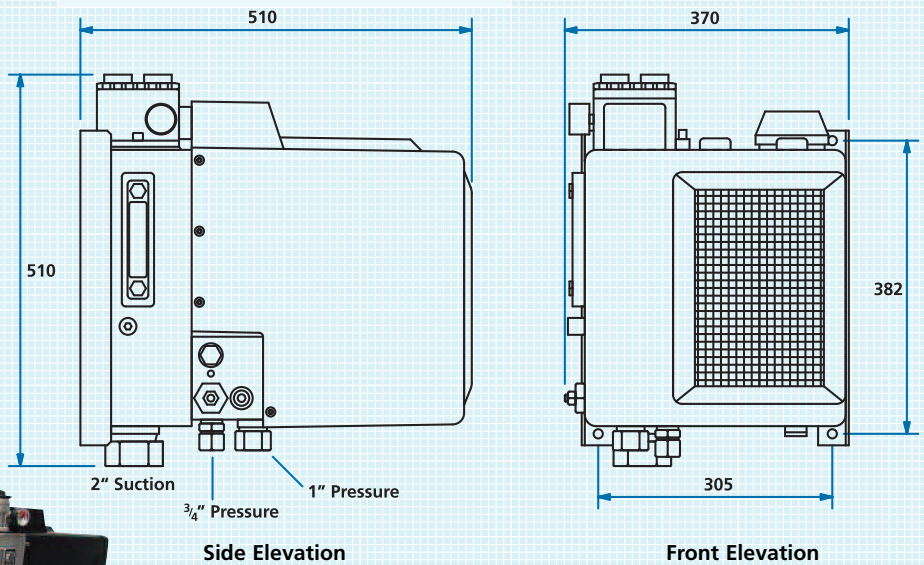

Other Transairvac products include:

- Hydraulic coolers
- Pressure line filters
- Compressors
- Vacuum pumps
- Blowers
- Rotary lobe pumps

TRANSAIRVAC
INTERNATIONAL LTD

Units 12 – 17, Croft Road Industrial Estate,
Newcastle, Staffordshire ST5 0TW
Tel: +44 (0)1782 710282 Fax: +44 (0)1782 710126
email: office@transairvac.com
web: www.transairvac.com