

PL TANKER PUMP

Rotary lobe pump for tanker loading and discharge

This small compact rotary lobe pump with next generation screw geometry lobes is proving to be a success with tanker operators. The close coupled hydraulic motor design is lightweight and compact. Easy access to the pumping chamber is a significant improvement on previous designs. The rubber coated impeller is able to handle significant solids contamination (waste sludge) without problems and the screw geometry means it is pulse free and very suitable for viscous liquid

Product features:

- Suitable for high solid content
- Pulsation free
- Mechanical seal
- Close coupled hydraulic drive arrangement
- Bidirectional to load or unload tanker
- Small footprint - high flow rate



TRANSAIRVAC
INTERNATIONAL LTD

www.transairvac.com



PL TANKER PUMP

TECHNICAL SPECIFICATION

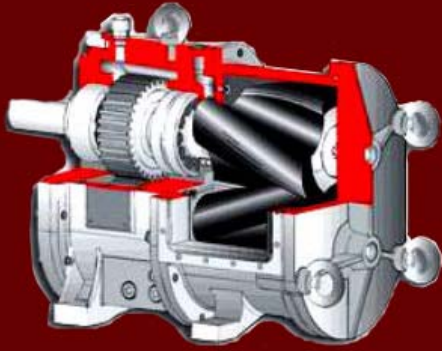

Performance

Flow rate	Pressure max	Speed	Power absorbed	Hydraulic Flow	Hydraulic Flow
m ³ /hr	bar	rpm	kW	Lt/min	Lt/min
54	6	400	16	50	192
70	6	500	20	62.5	192
84	6	600	24	75	192

Option:
Connection flange weld in



Connection flange transition piece
DN100 PN10/PN16

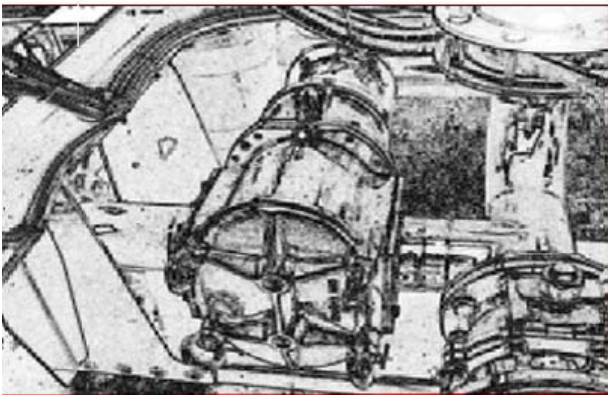
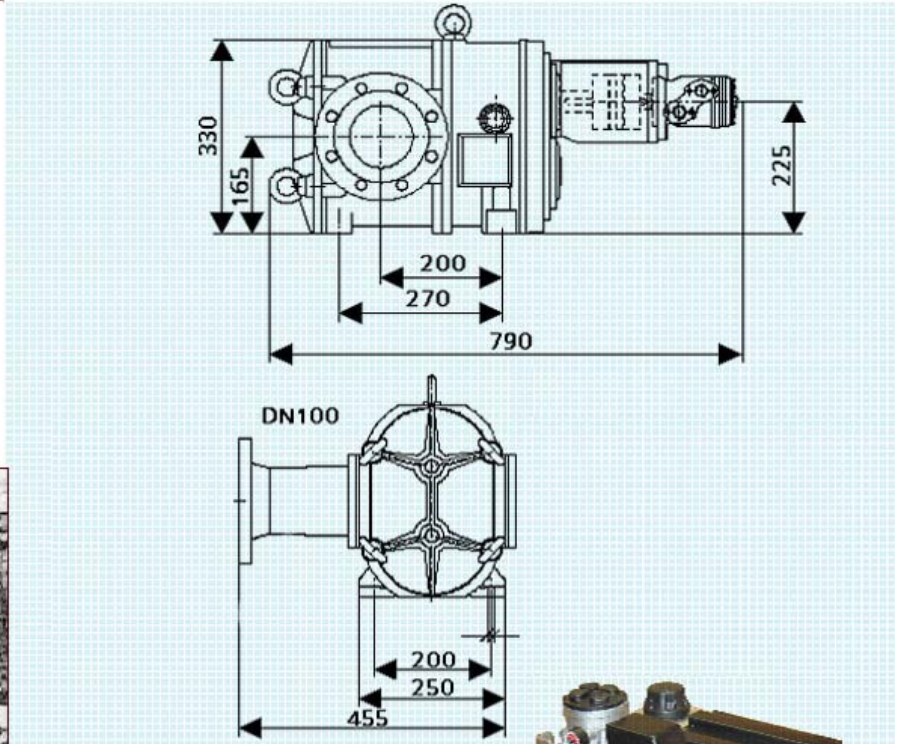

Other Transairvac products include:

- Hydraulic coolers
- Pressure line filters
- Compressors
- Vacuum pumps
- Blowers
- Rotary lobe pumps



TRANSAIRVAC
INTERNATIONAL LTD

Units 12 – 17, Croft Road Industrial Estate,
Newcastle, Staffordshire ST5 0TW
Tel: +44 (0)1782 710282 Fax: +44 (0)1782 710126
email: office@transairvac.com
web: www.transairvac.com