

PLF 500 FILTER

High quality filter industry approved performance (5 micron absolute)

Liquid Tanker Filter is an industry approved filter. It has excellent pressure drop characteristics and has a high dirt holding capacity

Giving you the adaptability you need

There are optional grades of filtration available

Product features

- Fully, stainless steel body
- Pleated stainless steel fibre element
- Gauge points
- Drain points

Options

- Other grade of filtration (80 micron)



PLF 500 FILTER

TECHNICAL SPECIFICATION

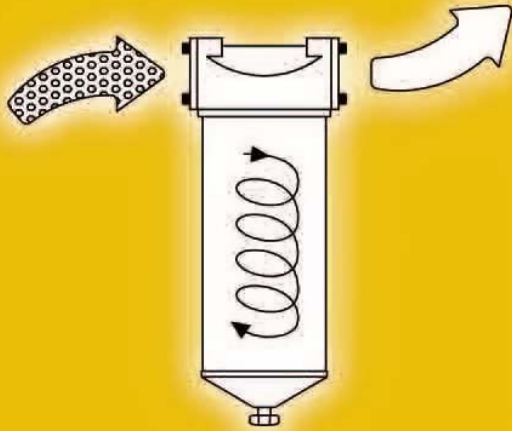

Flow rate m ³ /hr	400 – 800 m ³ /hr
Temperature rating	-30°C to +200°C
Filtration Efficiency	5micron absolute 100% 1micron @99.5%
Pressure rating	3barg rated 5 bar max

Filter Dimensions

Weight: 16kg size 3, 10kg size 2

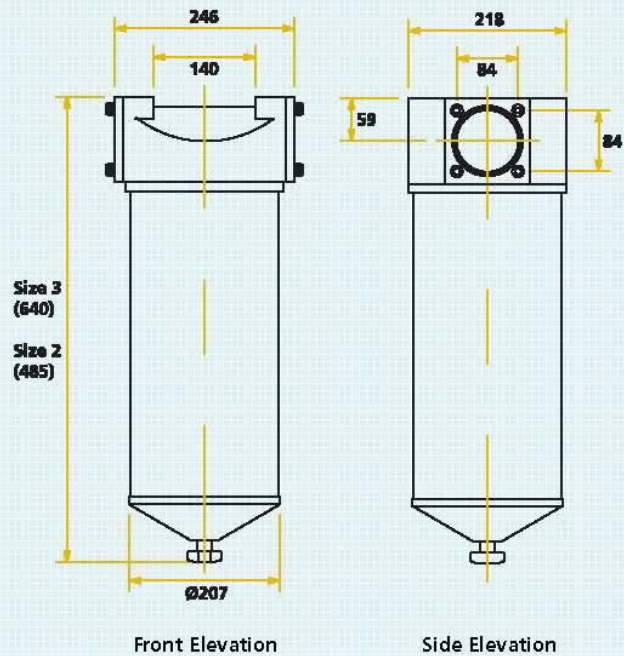

Pressure Drop Graph for Transflow Filter/Size 3

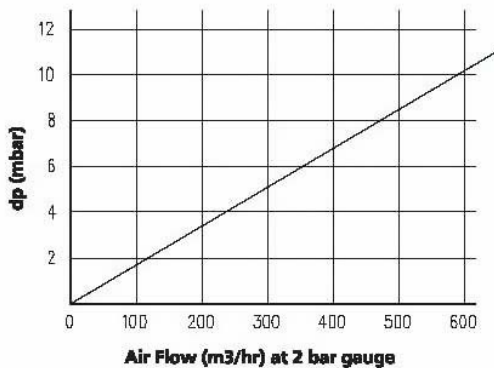

Other filter products available

PLF 150



Hiflow



Elements manufactured to customer specification



Other Transairvac products include:

- Hydraulic coolers
- Pressure line filters
- Compressors
- Vacuum pumps
- Blowers
- Rotary lobe pumps



Units 12 – 17, Croft Road Industrial Estate,
Newcastle, Staffordshire ST5 0TW
Tel: +44 (0)1782 710282 Fax: +44 (0)1782 710126
email: office@transairvac.com
web: www.transairvac.com