

TITAN II COMPRESSOR

The next generation of Compressor for liquid tanker discharge

Titan II is a contactless liquid tanker compressor, giving unparalleled performance in a virtually maintenance free unit. It is available with hydraulic drive which is commonly used in transport applications.

The Titan II uses the hook and claw principle to generate 2.5 Barg pressure, this delivers real performance with first class reliability.

The unit is also available on a frame, ready to mount on the chassis.

Product features

- Contactless (no vanes)
- Precision engineered
- Virtually maintenance free
- Low noise – 81 dB(A) @ 1m
- Optimal discharge times
- Air cooled
- Oil free

Accessories available

- Pressure Relief Valve
- Non Return Valve
- Air filter



TRANSAIRVAC
INTERNATIONAL LTD

www.transairvac.com



TITAN II COMPRESSOR

TECHNICAL SPECIFICATION

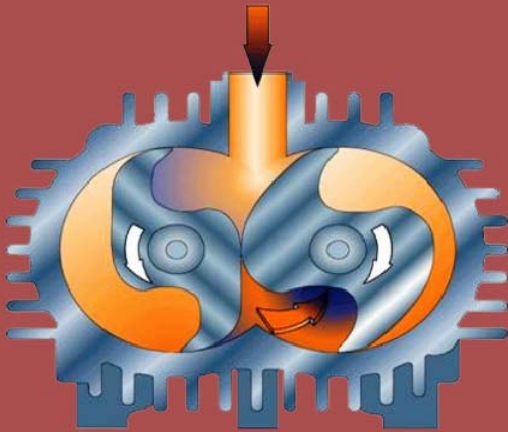

TITAN II PERFORMANCE

Flow Range	Pressure	Speed	Absorbed Power at 2 Barg pressure	Hydraulic Flow & Pressure
m ³ /hr	bar	rpm	kW	Lt/min & Bar
100	2.5	3000	9.0	60@120
130	2.5	3600	10.8	70@120

FEATURES

- Contactless (vane free) compressor
- Oil free
- 2.5 Barg continuously rated
- Air Cooled
- Low maintenance
- Low noise 81 dB(A) @ 1m
- 100 – 130 m³/hr
- Complete unit weight 130kg
- Hydraulic drive only



Dimensions

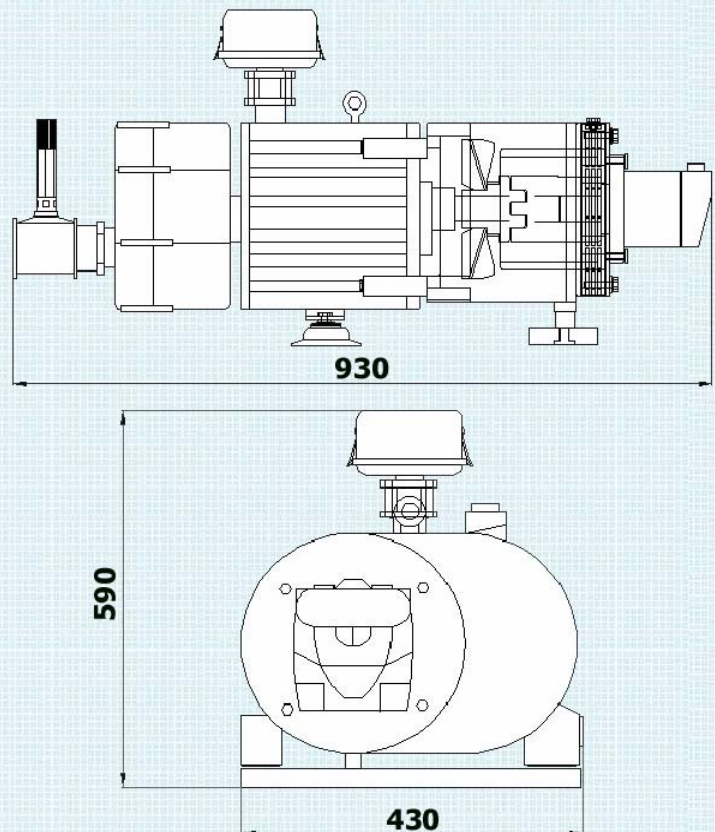

Other Transairvac products include:

- Hydraulic coolers
- Pressure line filters
- Compressors
- Vacuum pumps
- Blowers
- Rotary lobe pumps

TRANSAIRVAC
INTERNATIONAL LTD

Units 12 – 17, Croft Road Industrial Estate,
Newcastle, Staffordshire ST5 0TW
Tel: +44 (0)1782 710282 Fax: +44 (0)1782 710126
email: office@transairvac.com
web: www.transairvac.com